

# CH-1000

## Curtain Passive Infra-Red Detector



## Installation Instructions

### 1. INTRODUCTION

The CH-1000 curtain provides solid curtain coverage of maximum 13.5 m length x 6 m height (45 ft x 20 ft).

The CH-1000 may be used for perimeter protection, by setting up motion detection "curtains" along walls, large show windows, skylights and ceilings. It can also be used as an internal invisible barrier to detect movement between two adjacent areas. The CH-1000 can be mounted on the wall or on the ceiling.

A unique calibrated scale enables horizontal pattern adjustment of +7° to the left or to the right.

A double polarity, programmable pulse counter provides maximum immunity against environmental disturbances.

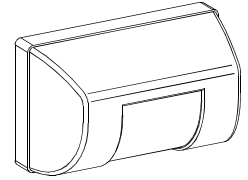

### 2. COVERAGE PATTERNS

Various mounting alternatives are available, each of which provides different coverage patterns as a solid curtain:

#### A. Wall Mounted (Figure 1)

The unit should be mounted on the wall at a maximum height of 6.0 m (20 ft). It provides solid curtain coverage, extending out from the mounting wall to the opposite wall up to a maximum distance of 13.5 m (45 ft) and down to the floor. The unit must be mounted horizontally, with the lens pointed downward, toward the floor.

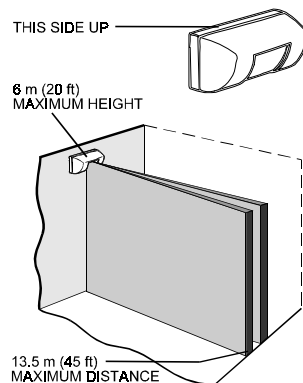

Figure 1. Wall Mounted Curtain

#### B. Ceiling Mounted (Figure 2)

The unit is mounted on the ceiling at a maximum height of 6.0 m (20 ft). It provides solid curtain coverage, extending down to the floor and away from the unit up to a maximum distance of 13.5 m (45 ft).

The unit must be mounted with the lens pointed towards the desired direction of the curtain coverage.

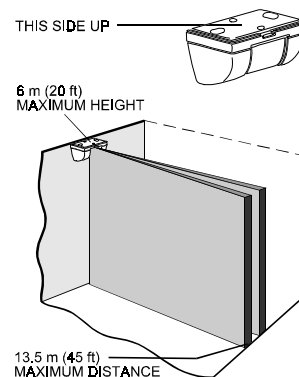

Figure 2. Ceiling Mounted Curtain

#### C. Pet Alley (Figure 3)

Pet-alley curtain can be created by installing the CH-1000 on the wall, near the floor, with the lens pointed toward the ceiling.

#### D. Skylight (Figure 4)

This method is useful for detection of entry through the ceiling or skylights. Install the unit as close as possible to the ceiling area or skylights to be protected and close to a corner of the protected area

**Note:** Maintain a minimum vertical distance of 0.5 m (1.5 ft) from the ceiling or skylights.

The unit is installed with its long axis vertical, so that the coverage pattern will be parallel to the floor (rotated 90° from the wall mounted installation - see Fig. 1). The maximum coverage of this installation is 5 x 5 m (17 x 17 ft). The field of view is 90° extending from the unit toward the opposite wall and along the wall on which the unit is mounted in the direction that the lens is facing.

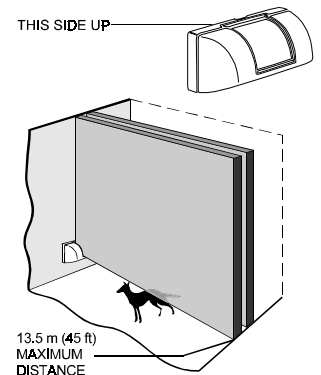

Figure 3. Pet Alley Curtain

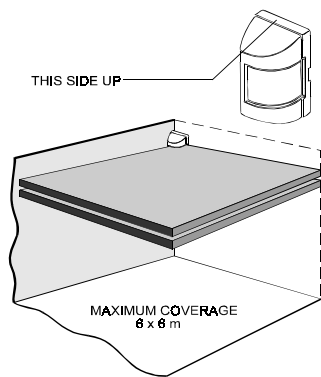

Figure 4. Skylight Solid Curtain

### 3. SPECIFICATIONS

#### OPTICAL

##### Detection Patterns:

Solid Curtain with maximum coverage pattern of 13.5 m length and 6 m height (45 x 20 ft). Other patterns see above.

**Adjustment:** Horizontal  $\pm 7^\circ$  calibrated to the left or right side.

#### ELECTRICAL

**Voltage:** 9 to 16 VDC.

**Current:** 20 mA.

**Relay Output:** Normally closed (tail safe) contacts. 18 ohm resistor in series with contacts. Rating - 0.1A resistive 24VDC.

**Alarm Period:** 2-5 seconds.

**Tamper Contacts:** Normally closed. Rating - 0.5A resistive/24 VDC.

**LED:** Walk Test - Enabled or disabled with internal link.

**Detector:** Dual-element low noise pyroelectric detector.

**Pulse Counter:** A selector for 1 / 2 pulses with opposite polarity.

#### MOUNTING

Wall or ceiling mounting.

#### ENVIRONMENTAL

**Operating Temperature:** 0° to 49°C (32°F to 120°F).

**Storage Temperature:** -20° to 60°C (-4°F to 140°F).

#### PHYSICAL

**Dimensions:** 105 x 65 x 53 mm (4.1 x 2.5 x 2.1 in.).

**Weight:** 90 g (3.2 oz)

**Color:** Soft White.

#### MODELS AVAILABLE

**CH-1000:** Standard model

**CH-1000S:** Same as CH-1000, but with Form-1C relay contacts.

# 4. INSTALLATION

## 4.1 Mounting

The CH-1000 PIR can be installed on the wall or on the ceiling, according to the specific application as described in Section 1.

The maximum mounting height is 6 m (20 ft).

**A.** Select the mounting location so that the expected motion path of an intruder will cross the curtain pattern. Refer to Section 2 for a detailed description of the mounting alternatives and their respective coverage patterns.

**Note:** *Passive infrared detectors are sensitive to changes in infrared energy caused by an object moving across the unit's field of view. Under certain temperature and background conditions, in which the temperature difference is too small, the PIR may fail to respond. It is therefore recommended that the PIR be aimed toward the coolest place in the protected area, in order to obtain the maximum sensitivity.*

**B.** Select the mounting height according to the maximum required coverage range. For maximum sensitivity do not install the CH-1000 higher than necessary. For normal applications it is recommended to install the unit between 2.7 and 3 m height (9 to 12 ft).

**C.** With CH-1000 pet-alley coverage pattern, it is recommended that the sensor be installed at the lowest possible height that still enables the pets to move below the curtain pattern without being detected.

**D.** CH-1000 is extremely immune to air turbulence and RFI. However, to minimize possible false alarms, it is highly recommended to avoid aiming the detector at heaters, sources of light, or windows subjected to direct sunlight. Also avoid running wiring close to high power electrical cables.

**E.** Open the cover by gently inserting a quarter-inch screwdriver in the slot at the bottom of the unit, between the front cover and the base. Twist the screwdriver slightly until the cover swings outward and removes easily.

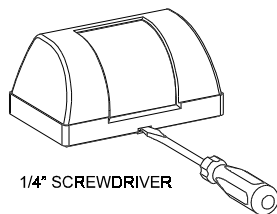

Figure 5. Removing the Cover

**F.** Mount the base (equipped with the printed circuit board) in the location and height selected for optimum coverage. Use the two elongated mounting holes at the back of the base. The unit must be fastened firmly to the mounting surface to avoid possible vibrations.

## 4.2 Wiring

Route the wires into the detector via the wiring knockouts. See Figure 7.

Connect wires to the terminal block in the following order. Refer to Figure 6.

\* Model CH1000S only

**A.** Connect the **Tamper N.C.** terminals to a normally closed 24-hour protection zone of the control panel. Tamper contact will open when cover is removed.

**B.** Connect the **Relay N.C.** terminals to a normally closed burglar protection zone of the control panel. Relay contacts will open when a motion is detected or during power loss. The relay contacts are rated at 100 mA, 24 VDC maximum (resistive load only). An 18 ohm resistor is internally connected in series with the relay contacts.

**Note:** *Model CH-1000S provides changeover Form-1C relay contacts (i.e. N.C. + N.O.).*

**C.** Connect the **12 VDC (+)** and **(-)** terminals to a 9 to 16 Volt DC power source and check for correct polarity. It is advisable that the power supply be battery backed-up. The current drain of each sensor is approximately 20 mA.

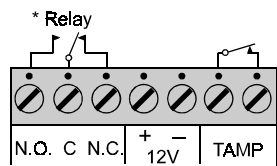

Figure 6. Terminal Block

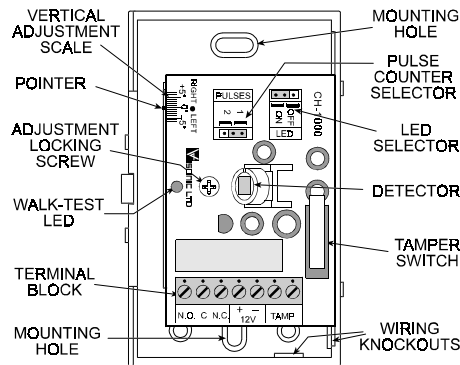

Figure 7. Printed Circuit Board

## 4.3 Curtain Adjustment

The calibrated adjustment scale (printed on the left corner of the p.c. board) and the plastic pointer on the base indicate in degrees the approximate horizontal angle between the center line of the unit and the direction of the curtain pattern.

The scale enables fast and easy adjustment of the curtain to the left or to the right of about 7° in either direction.

As shipped, all CH-1000 detectors are factory-preset to 0°. To change the horizontal pattern adjustment, loosen the screw which fastens the printed circuit board to the base. Slide the p.c. board to the left or to the right as desired and tighten the screw firmly.

The markings "left" and "right" on the p.c. board indicate the direction of the pattern adjustment, relative to the unit, as viewed from the unit in the direction of the curtain pattern.

## 4.4 Setting the Pulse Counter

The CH-1000 is equipped with a selectable pulse counter which can be set to count two consecutive pulses with opposite polarity, before activating the alarm relay. This pulse counter logic requires that the moving person will cross both sides of the curtain pattern, which correspond to the two elements of the dual detector. This provides maximum protection against false alarms caused by environmental disturbances.

**A. 2-pulse setting:** The two-pulse logic may be selected only when the CH-1000 is installed in cold or temperature-controlled locations and where the installation height is less than 3.6 m (12 ft) and the required coverage range is less than 9.0 m (30 ft). Otherwise, one pulse should be selected.

**B. 1-pulse setting:** This setting actually disables the pulse counter. It should be used when maximum detecting sensitivity or fast "catch" performance are of highest importance, such as in high security installations.

## 4.5 Walk Test

**A.** Apply 12 VDC power and allow five minutes for the unit to warm up and stabilize before testing.

**B.** Adjust the curtain position as explained in Para. 4.3.

**C.** Set the pulse counter per Para. 4.4 above.

**D.** Walk-test the coverage area by crossing the curtain from one side to the other (in opposite directions) and observe the LED. The LED lights up whenever the unit detects your motion. Allow 10 seconds between each test for the unit to stabilize. Repeat the test in various locations and distances from the detector up to the far end of the desired coverage range.

**E.** After testing, the LED can be disabled to prevent unauthorized persons from tracing the coverage pattern. To disable the LED, set the jumper marked "LED" to the OFF position.

**NOTE:** *The range and the coverage area should be checked by an alarm technician at least once a year. To assure proper continuous functioning, the user should be instructed to perform a walk test at the far end of the coverage pattern to assure an alarm signal prior to each time the alarm system is armed.*

## WARRANTY

Visonic Ltd. and/or its subsidiaries and its affiliates ("the Manufacturer") warrants its products hereinafter referred to as "the Product" or "Products" to be in conformance with its own plans and specifications and to be free of defects in materials and workmanship under normal use and service for a period of twelve months from the date of shipment by the Manufacturer. The Manufacturer's obligations shall be limited within the warranty period, at its option, to repair or replace the product or any part thereof. The Manufacturer shall not be responsible for dismantling and/or reinstallation charges. To exercise the warranty the product must be returned to the Manufacturer freight prepaid and insured.

**This warranty does not apply in the following cases:** improper installation, misuse, failure to follow installation and operating instructions, alteration, abuse, accident or tampering, and repair by anyone other than the Manufacturer.

This warranty is exclusive and expressly in lieu of all other warranties, obligations or liabilities, whether written, oral, express or implied, including any warranty of merchantability or fitness for a particular purpose, or otherwise. In no case shall the Manufacturer be liable to anyone for any consequential or incidental damages for breach of this warranty or any other warranties whatsoever, as aforesaid.

This warranty shall not be modified, varied or extended, and the Manufacturer does not authorize any person to act on its behalf in the modification, variation or extension of this warranty. This warranty shall apply to the Product only. All products, accessories or attachments of others used in conjunction with the Product, including batteries, shall be covered solely by their own warranty, if any. The Manufacturer shall not be liable for any damage or loss whatsoever, whether directly, indirectly, incidentally, consequentially or otherwise, caused by the malfunction of the Product due to products, accessories, or attachments of others, including batteries, used in conjunction with the Products.

The Manufacturer does not represent that its Product may not be compromised and/or circumvented, or that the Product will prevent any death, personal and/or bodily injury and/or damage to property resulting from burglary, robbery, fire or otherwise, or that the Product will in all cases provide adequate warning or protection. User understands that a properly installed and maintained alarm may only reduce the risk of events such as burglary, robbery, and fire without warning, but it is not insurance or a guarantee that such will not occur or that there will be no death, personal damage and/or damage to property as a result.

**The Manufacturer shall have no liability for any death, personal and/or bodily injury and/or damage to property or other loss whether direct, indirect, incidental, consequential or otherwise, based on a claim that the Product failed to function.** However, if the Manufacturer is held liable, whether directly or indirectly, for any loss or damage arising under this limited warranty or otherwise, regardless of cause or origin, the Manufacturer's maximum liability shall not in any case exceed the purchase price of the Product, which shall be fixed as liquidated damages and not as a penalty, and shall be the complete and exclusive remedy against the Manufacturer.

**Warning:** The user should follow the installation and operation instructions and among other things test the Product and the whole system at least once a week. For various reasons, including, but not limited to, changes in environmental conditions, electric or electronic disruptions and tampering, the Product may not perform as expected. The user is advised to take all necessary precautions for his /her safety and the protection of his/her property.

6/91



VISONIC LTD (ISRAEL): P.O.B 22020 TEL-AVIV 61220 ISRAEL. PHONE: (972-3) 645-6789, FAX: (972-3) 645-6788

VISONIC INC. (U.S.A.): 10 NORTHWOOD DRIVE, BLOOMFIELD CT. 06002-1911. PHONE: (860) 243-0833, (800) 223-0020 FAX: (860) 242-8094

VISONIC LTD. (UK): UNIT 1, STRATTON PARK, DUNTON LANE BIGGLESWADE, BEDS. SG18 8QS. PHONE: (01767) 600857 FAX: (01767) 601098

VISONIC LTD. 1998 CH-1000 D-1100-0 NEW : DE1100- (REV. 4, 4/98)



MADE IN  
ISRAEL